

Ag And Industrial Separators

Capacity: 200 to 7800 GPM.
Pressure Rating: 150 lb. standard for long life. For higher ratings, contact factory
Flow into Separator: Standard counter-clockwise facing outlet. Clockwise rotation is available.
Sand Removal Efficiency: 98% of solids down to 200 mesh.
Pressure Drop: See curves for proper size.
Automatic Purge System: Available at low cost.
Strong: 1/4" carbon steel construction.

Model	GPM	Flow M3/Hr	Size	Shipping Length	(Lbs.)
R40LA	200-400	46-92	4"	87"	280
R60LA LF	365-700	84-161	6"	115 1/2"	493
R60LA HF	500-950	115-219	6"	115 1/2"	493
R80LA	800-1600	184-369	8"	124 3/4"	722
R100LA	1300-2300	299-529	10"	135"	840
R120LA	2025-3400	465-782	12"	156"	1400
R140LA	2975-5000	684-1150	14"	167"	2000
R160LA	4000-6200	920-1426	16"	182"	2310
R180LA	5000-7800	1150-1794	18"	192"	2750

Dimensions

Inlet/Outlet	4"	LF6"	HF6"	8"	10"	12"	14"	16"	18"
A	48 1/2"	63"	63"	71"	78"	102"	102 1/2"	108"	118 1/2"
B	46 1/2"	59 1/2"	59 1/2"	65"	71"	75 1/4"	85 3/8"	89 1/4"	98 1/4"
C	46 1/2"	60 3/8"	58 3/4"	66"	72 3/4"	76 1/2"	86 5/8"	90"	100 1/4"
D	16"	20 1/2"	20 1/2"	21 3/4"	21"	23 3/4"	24 1/2"	24 3/8"	27"
E	19"	20 3/4"	20 3/4"	22 5/8"	24 1/2"	26 5/8"	27 3/4"	29"	33 5/8"
F	7 1/2"	10 1/2"	10 1/2"	12"	13"	14 1/4"	12"	12"	15"
G	19"	22"	22"	24 1/2"	29"	32"	33 1/2"	33 1/2"	34 1/2"
H	4"	5 3/4"	5 1/4"	5 5/8"	7"	8 1/8"	9"	9"	11"
J	6 5/8"	10 3/4"	10 3/4"	12 3/4"	16"	18"	20"	24"	28"
K	12"	16"	16"	18"	22"	26"	28"	30"	36"
L	80"	106 1/4"	106 1/4"	114"	123 1/2"	139"	152 1/2"	160"	177"
M	1/4"	1/4"	1/4"	1/4"	1/4"	1/4"	1/4"	1/4"	1/4"
N	5"	5"	5"	5"	5"	5"	6"	6"	6"
P	1"	1"	1"	1"	1"	1"	1"	1"	1"
X	22"	30"	30"	34"	42"	50"	50"	54"	57 3/4"
Y	14"	14"	14"	16"	20"	24"	26"	28"	29 3/4"

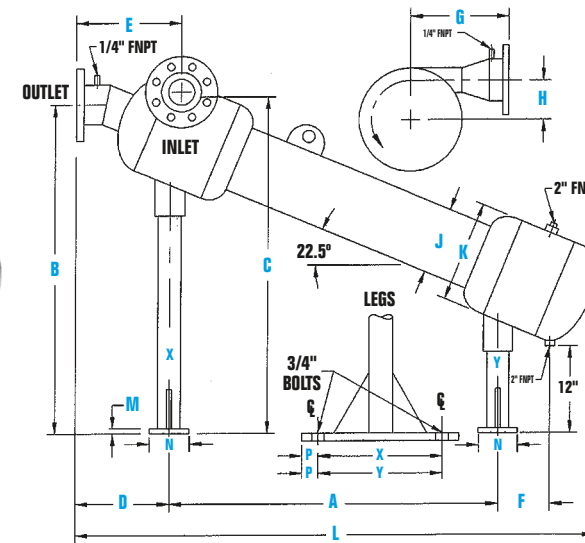
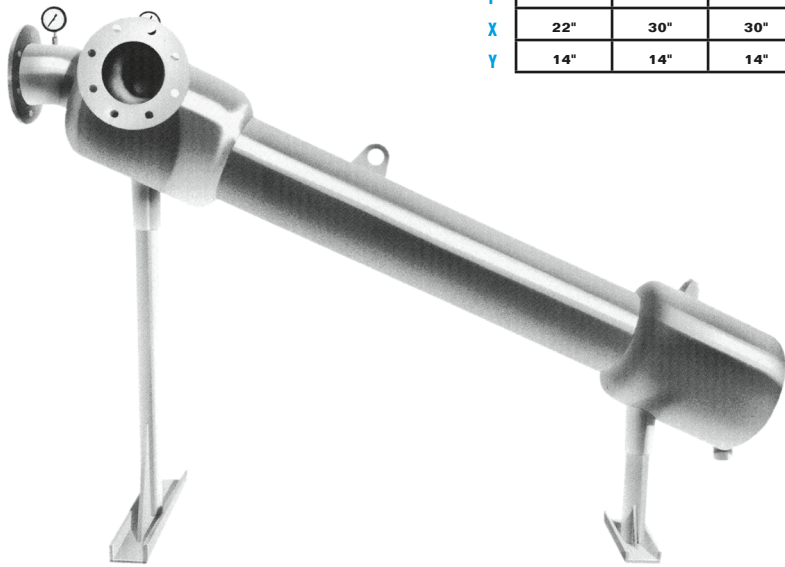

Flow and Pressure Drop Chart

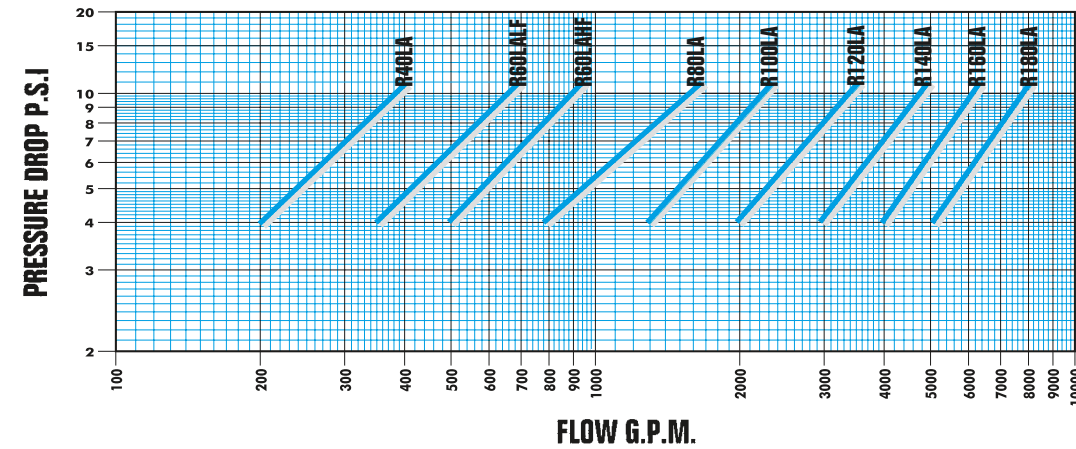

Clemons Centrifugal Sand Separator

Does the Dirty Work For You

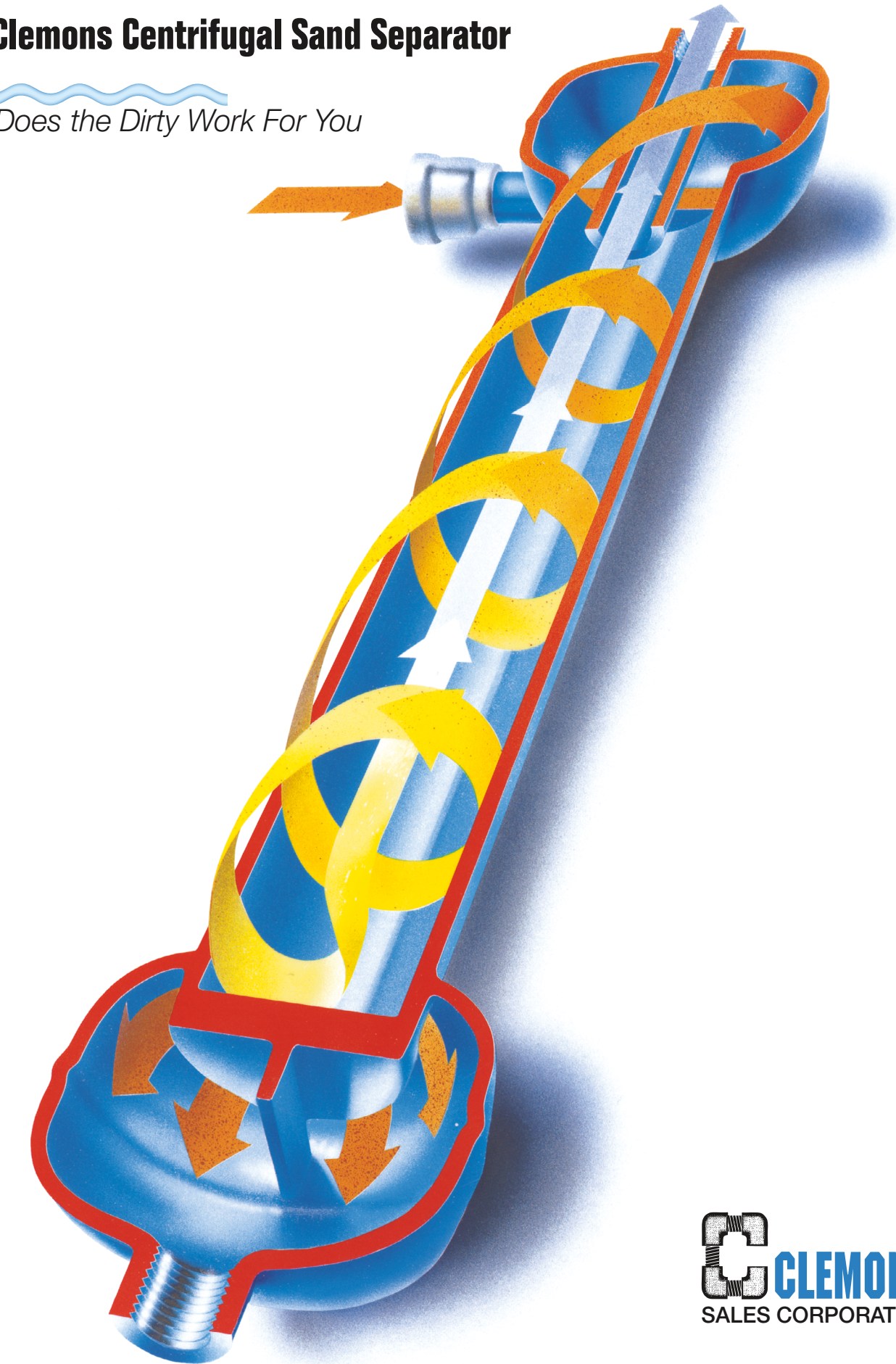

Manufacturers and Distributors of Irrigation and Industrial Equipment
 6983 Supply Way • Boise, Idaho 83716
 (208) 345-2525 / Toll Free 1-800-635-5975
 FAX 1-208-345-2143
 www.clemonssales.net
 e-mail sales@clemonssales.net



Anyone who irrigates or pumps water for any purpose – irrigation, industrial, turf or private and public water systems – knows their greatest enemy is sand, silt and grit. These elements reduce efficiency of equipment by plugging and clogging sprinklers, drip emitters, valves and spray nozzles. They also cost time and money in repairs, replacement parts, downtime, wasted energy and a loss of productivity. Decreased efficiency is also a major problem as nozzles gradually clog up or wear out, lowering productivity until replacement occurs. The solution: the Clemons Sand Separator manufactured by Clemons Sales, Inc. The Clemons Centrifugal Sand Separator – designed for easy installation – removes 98 percent of 200 mesh or larger sand, grit and other solids heavier than water before entering expensive equipment. Liq-

uids/solids enter the unit and set up a circular flow with centrifugal action tossing heavier abrasives downward in a spiral motion to the separation chamber. There, the particles drop into the separator's collection chamber and are purged from the system. The purified water is drawn to the separator's vortex and up through the outlet. It can now be dispersed to irrigation equipment without causing clogging, plugging or wear.

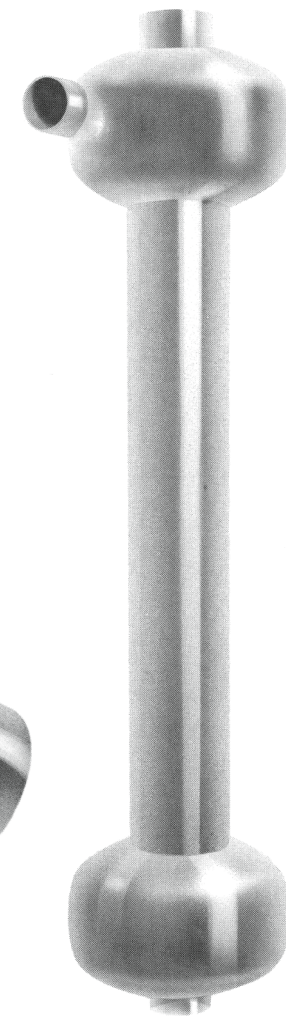
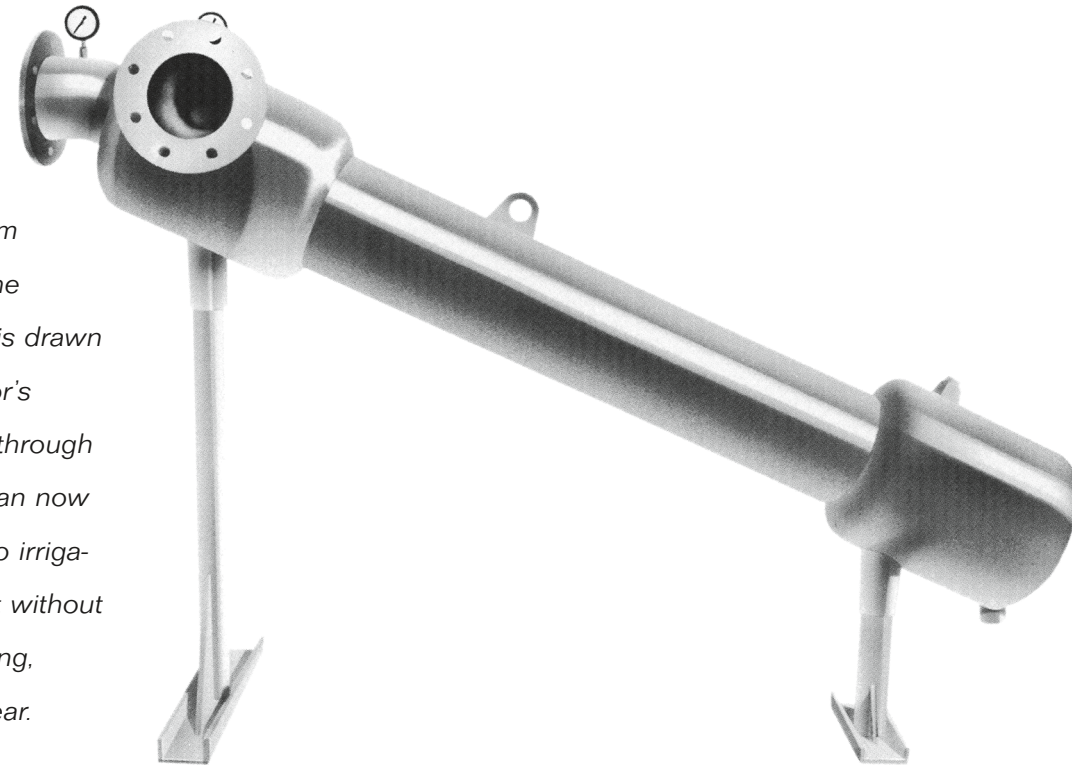

How to Select the Right Separator

The Clemons Separator is for all types of irrigation, industrial and agricultural systems – low or high pressure – and offers one to meet every individual's needs. To select the proper model, first identify the specific problem. This involves deciding where the separator will be used.

Next, confirm the minimum and maximum gallonage to be handled and the operating pressure to allow the unit to perform most efficiently. Figure the speed of inlet water to the separator of 3 1/2 feet per second minimum. Clemons offers separators to handle flows ranging from 5 to 7800 U.S. GPMs, and can handle operating pressures up to 150 pounds (see charts).

Lastly, determine the amount of solids to be dumped and the desired purging technique – by hand or automated. The collection chamber should not be more than half full. An automatic purge valve should be used with all separators. Separated particles must be removed on a regular basis to prevent the separator from becoming "sand bound" (see "Accessories" for options).

The Clemons Separator is the best solution for your clogging problems. Its superior, heavy construction makes it the best choice, whatever your application. Best of all, since it has no moving parts, screens, filter media or backwash, the device is trouble-free, making it worry free.

Warranty

All equipment manufactured by Clemons Sales Corp. is unconditionally warranted against defective materials and workmanship for a period of one year from the date of delivery.

The liability under this warranty is limited to servicing or adjusting any equipment returned to the factory for that purpose and to repair or replace any defective parts thereof. If a fault develops, notify us, giving a complete description of the malfunction; include the model number and delivery date of the unit. We will review this information and supply you with either service data or shipping instructions. After receiving shipping instructions, forward the equipment prepaid to the factory or to the authorized dealer indicated on the instructions.

Installation

All Clemons Separators are designed for easy installation. Large units have self-supporting legs with slots for anchor bolts and inlet piping can be for either clockwise or for counter-clockwise rotation. The units are shipped on skids or completely assembled. Large units are assembled as follows:

- ❑ A concrete foundation 12 inches square by a length 8 inches longer than the channel leg base should be placed under each leg with anchor bolts inserted in the concrete and some reinforcing steel. A lifting eye is supplied to assist in placing the separator body.
- ❑ Install pressure gauges on the 1/4 inch fittings.
- ❑ A 1/2 inch outlet is on the discharge pipe of the separator – this is to supply clean water down to the electric valve diaphragms where the sand is blown off.
- ❑ In and out piping to the separator should have a straight run of at least 5 pipe diameters in order to quiet the water down or straightening veins if less than 5 pipe diameters.

- ❑ DO NOT use thin wall elbows – these set up a vibration in the separator use smooth radius elbows. Check valves should be placed ahead of the separator. A vacuum relief valve should be placed up-stream from the separator. An automatic flush valve should be placed on the sand blow-off connection. These are inexpensive and are available in various types.

Small separators can be wall mounted, hung on the main piping, or placed on legs if ordered that way. Installation for both small and large units can be achieved by the following:

- ❑ Connect separator discharge to clean liquid pipeline using short nipples and union – same size as the separator discharge coupler.
- ❑ Install nipple and purge valve – same size as purge coupler.
- ❑ Using the bell reducer, supplied with the vertical separator, connect the separator inlet to the pipe carrying solid-laden liquid.

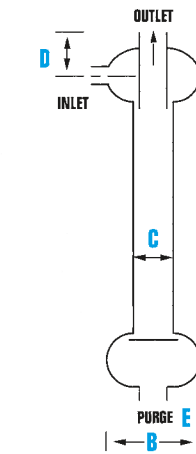
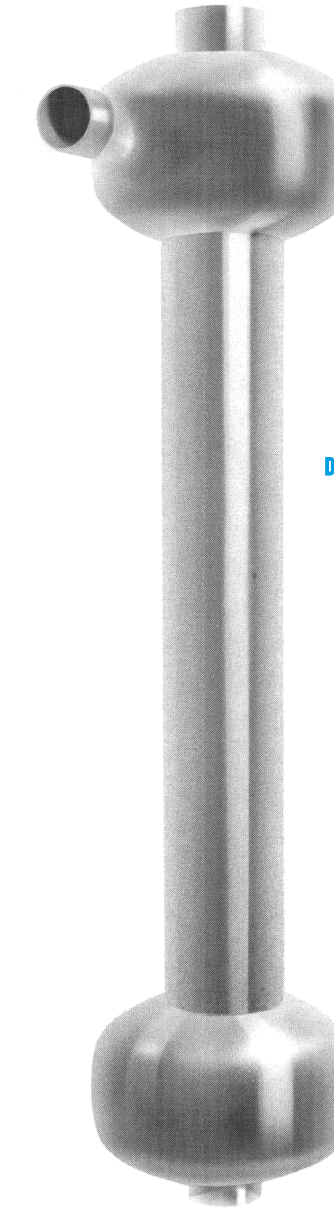

Vertical In-Line Separators

Model	GPM	Flow M3/Hr	Size	Length	[Lbs.]
R5V	4-10	.9-2.3	1/2"	21 1/2"	13
R7V	10-20	2.3-4.6	3/4"	21 1/2"	15
R10V	18-38	4.8-7	1"	30 1/2"	26
R12V	26-52	6-12	1 1/4"	30 1/2"	26
R15V	38-79	8.7-18	1 1/2"	30 1/2"	26
R20V	63-120	14.5-27.6	2"	38"	44
R25V	100-180	23-41.4	2 1/2"	44"	55
R30V	125-260	28.8-59.8	3"	48"	75
R40V	190-345	43.7-79.4	4"	49"	120

Dimensions

Inlet Outlet	1/2"	3/4"	1"	1 1/4"	1 1/2"	2"	2 1/2"	3"	4"
A	21 1/2"	21 1/2"	30 1/2"	30 1/2"	30 1/2"	38"	44"	48"	49"
B	6"	6"	6"	6"	6"	8"	10"	10"	12"
C	2 3/8"	2 3/8"	3 3/8"	3 3/8"	3 3/8"	4 1/2"	4 1/2"	5 1/2"	6 5/8"
D	2 1/2"	2 1/2"	2 1/2"	2 3/4"	2 3/4"	3 1/4"	4 1/2"	4 7/8"	6 1/2"
E	1"	1"	1"	1"	1"	2"	2"	2"	2"

Flow and Pressure Drop Chart

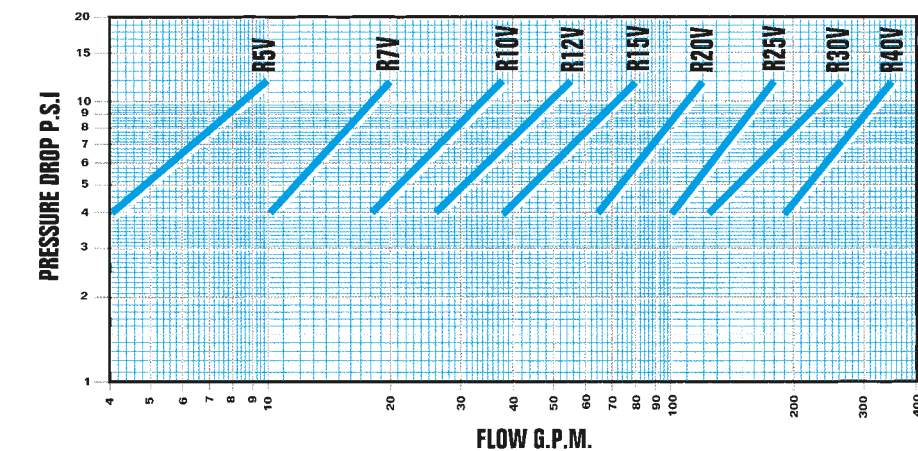

Normal Use: Between pump and system above ground.

Protects: Equipment between 5 and 345 GPM.

Ideal: For domestic house lines, sprinkler systems and industrial equipment.

Pressure Drop: See curves for proper size

Larger Pipes or Volumes: See Clemons Ag Separator Section.

Backwash Time and Waste: Install Clemons Separator ahead of sand filter for reductions.

Minimum Fine Sand Passage: Where this is not acceptable, use a Clemons Separator ahead of a fine filter.

Automatic Sand Blowoff: Excellent systems are available when desired (see "Accessories").

Modifications: Can be made for low operating pressures.

Installation: Mount upright. Place gate valve or hose bibb on blowoff at bottom of separator. Release sand often enough to keep sand build-up at minimum. Intermittent operation will permit some fines to pass through separator.